

PS - 4

High-Voltage Power Supply & Heater Regulator **USER GUIDE**

04/12/2010

Contents

Page	1	PS-4 PCB Overview
	1	Introduction to Power Supplies
	2	Standard Power Supplies
	2	The Function of a Power Supply
	2	Wall Outlet Voltage Problems
	4	The Parts of a Power Supply
	4	Transformers
	6	Rectifiers
	6	Capacitors
	9	Types of Electrolytic Capacitors
	10	Capacitor Safety
	11	Rectifier Circuits
	12	Voltage Doubler Circuits
	13	Voltage Regulators
	14	PS-4 HV Schematic & Part Values
	15	Heater Power Supply & Regulator
	17	Modifications & Part Upgrades
	17	Operation
	18	Assembly and Testing
	19	Grounding
	20	PCB Dimensions

DANGER!

This PCB holds a high-voltage power supply; thus, a real—and possibly—lethal shock hazard exists.

Ideally, a variac should be used to slowly power up the regulator, as it is better to have a mis-oriented electrolytic capacitor or a mis-located resistor blow at low voltages, rather than at high voltages. Remember that the danger increases by the square of the voltage; for example, 200 volts is four times more dangerous than 100 volts and 400 volts is sixteen times more dangerous.

Once the power supply is powered up, be cautious at all times. In fact, even when the power supply is disconnected or shut down, assume that power-supply capacitors will have retained their charge and, thus, can still shock. If you are not an experienced electrical practitioner, before attaching the transformer windings to the board, have someone who is well-experienced in electronics review your work.

There are too few tube-loving solder slingers left; we cannot afford to lose any more.

GlassWare
AUDIO DESIGN
www.glass-ware.com
www.tubecad.com

sales@glass-ware.com

Copyright © 2010
All Rights Reserved

PS-4 PCB

The PS-4 circuit board makes life quite a bit easier for the tube fancier. On this small four by four inch, extra thick (0.094), 2oz-copper traces, USA-made PCB resides both a high-voltage power supply and a low-voltage regulator, with each finding its own raw power supply, including the rectifiers and power-supply reservoir capacitors. In other words, except for the power transformers, the PS-4 PCB holds all that is needed to make a fine tube-circuit power supply.

The low-voltage regulator is meant to power the tube heaters; the high-voltage power supply, the rest of the tube circuit. The low-voltage regulator's power supply is flexible enough to allow either a conventional full-wave-bridge rectifier arrangement or a two-rectifier voltage-doubler configuration, allowing for more latitude in power transformer selection; this regulator can be set to either 6.3V or 12V or 12.6V.

The high-voltage portion of the PS-4 power supply uses a tube rectifier, a simple RC filter to achieve a fairly quiet B+ voltage, which can span from 200V to 300V. (The series resistor can be replaced by an external choke.)

In addition, the PS-4 can DC reference the heater regulator to ground or 1/4 the B= voltage or left floating, with only a coupling capacitor to ground.

Introduction to Power Supplies

For most modern electronic products—printers, alarm clocks, LCD photo frames—the power supply is the least important portion of the package. Which helps explain why cheap, small, switching, universal, wall-wart power supplies fill every available outlet in most houses. All proficient tube-circuit designers must master the subtleties of creating a clean DC voltage. For although a heater may be powered by either an AC or DC power supply, a DC power supply is always necessary, as the remaining portion of the tube circuit requires solely DC voltage.

With audio circuits, the cleaner, the steadier, the lower and the flatter in output impedance across the audio band of frequencies, the better suited that power supply is for audio use. A good metaphor is that the audio gear is the film in a movie projector and the high-intensity light source is the power supply; the whiter and steadier the light, the better the picture.

Paradoxically enough, high-voltage power supplies are at once both the easiest and the most challenging element of tube electronics. Requiring as little as one transformer, diode, and capacitor, what could be simpler? Or utilizing as much as a several power transformers, many precision voltage references, twelve rectifier bridges, a score of high-voltage MOSFETs, a fistful of OpAmps, dozens of capacitors, a cup of individual diodes, and several hundred resistors, what could be more complex?

This high voltage power supply belongs to the simpler camp. Its tube rectifier allows a slow start up voltage and provides that certain something, which only tube rectifiers can deliver. The RC filter used is a simple affair, consisting of single power resistor and additional shunting capacitor. What follows is an overview of power supplies in general, with the PS-4's design and construction at the end.

Standard Power Supplies

A “standard power supply” is one that is not regulated. A standard power supply can be simple or complex, unipolar or bipolar, low voltage or high voltage, low current or high current, vacuum tube rectified or solid state rectified, choke-free or choke-filled—the only disqualification is having a regulator. As most regulated supplies must also incorporate a standard power supply as their voltage source, an understanding of the standard power supply is primary to understanding voltage regulation.

The Function of a Power Supply

Obviously, a power supply’s purpose is to provide a power source for a circuit. However, we should take one step back and consider why the wall outlet cannot serve directly as a power supply for a tube circuit, since it does so for a lamp or toaster. The simple answer is that the wall outlet provides an AC voltage and audio tube circuits require a DC voltage. A more complete answer is that a power supply not only converts the AC voltage into DC, additionally, it converts the value of the AC voltage and it modifies the resulting DC voltage by smoothing, stabilizing, current limiting, and removing much of the radio frequency interference (RFI) from it. All of these functions are not needed by a lamp or toaster, but are essential for a tube circuit. Actually, the only safe assumption concerning the wall voltage is that its time base is accurate. Beyond frequency, there is much latitude—sadly, too much latitude.

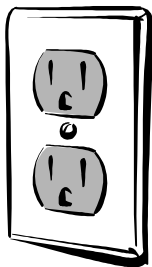

Wall outlet voltage problems:

- **Voltage varies**
- **RFI contamination**
- **AC voltage may contain a DC component**

The wall voltage is not as fixed as you might imagine, as the wall voltage varies from city to city, and within the same city, from hour to hour. It has slowly risen over the decades. For example, truly old transformers bear stickers that specify a 110Vac or 112Vac input voltage; whereas, a newer transformer sticker might read 117Vac or 120Vac. In many new developments, the wall voltage runs hot, at 122Vac or hotter; whereas in an old Victorian apartment, it can run cold, at 110Vac or less, because of the long skinny wall wiring used. The wall voltage varies depending on the varying load presented to the power line feeding your house. During peak use it drops and, when unburdened, it climbs. (Indeed, if a power line on the street is ruptured, thus unloading the load down from the break, the voltage can climb to scary heights.)

Although a power-supply designer would disagree, as far as the utility company is concerned, +/-10Vac variations in wall voltage are perfectly acceptable. But these voltage variations can cause trouble. A standard power supply’s output voltage will vary with the change in wall voltage. For example, a power amplifier’s B+ voltage could drop or rise 50 volts from being used in one city versus another. Now, +/-50 volts is a lot of voltage variation; in fact, it might be more than half the voltage drop across a pass device in a high voltage regulator.

Maximum and Minimum Wall Voltages A reasonable guess on the absolute upper limit of sustained higher line voltage would be around 127vac in the USA, as the power company—which could be held liable for damaging your microwave oven, if the voltage became too hot—is very quick to prevent an over-voltage. The lower limit is usually set to around 108vac here in the USA. You can, however, choose to design around an even wider variation, say 100-130vac.

RFI The art and science of stripping away RFI can fill a large book. Radio frequency interference comes from more than just radio stations. Light dimmers, computers, cable TV, hair dryers, switching power supplies, industrial electronics—all can pollute the wall voltage with RFI. In general, assume that the wall voltage is moderately contaminated with RFI and provide some means for scrubbing it clean. Sometimes adding a small shunting capacitor after the fuse on the primary is all that is needed; at other times, many complex RF filters are required on both the primary and secondary.

AC Plus Some DC Every electronic student knows that the wall outlet provides AC voltage; few, however, know that it might carry a DC component as well. This DC voltage can be as great as a few volts and it is usually the result of an industrial power supply back-feeding some DC into the line. Since the power supply contains a transformer, we imagine that this DC voltage can have no effect on our power supply. Unfortunately, we are not that lucky.

The transformer was designed for a strictly AC use, which means that its core was not designed to be used in the presence of a DC current. If a DC current passes through a transformer winding, the core will tend to polarize, that is the molecules within the iron core material will move from their flexible orientation into one unified direction. The result of polarization of the core is that the transformer begins to resemble an electromagnet, which can quickly saturate the core material and radically decrease its effective inductance. In other words, the presence of DC across a winding of a normal AC transformer will make the transformer much less effective at transferring energy.

Paradoxically, the better the transformer, the worse the saturation problem. A toroidal transformer is much more sensitive to a DC current, as it is a much tighter inductive design. In contrast, the standard EI-core transformer is a looser inductive design and this looseness allows it to sustain a greater amount of saturation. What is going on here is that all transformers contain some sloppiness in their electromagnetic circuit, as their physical construction is not perfect, and this sloppiness constitutes a parasitic air gap. This air gap works like the purposeful air gap in a single ended transformer by increasing the saturation threshold of the transformer's core.

Beyond reduced efficiency and poorer regulation, what are the ramifications of a DC component on the wall voltage? Here is a possible scenario: you have just built a supremely wonderful single ended amplifier, an amplifier so sweet and bewitching that if Shakespeare had heard it, he would have been compelled to write an additional twenty sonnets. Yet, when you bring it to your friend's house, it sounds unbelievably noisy and harsh. What happened? Probably his wall connection contained a unhealthy amount of DC and this so saturated the core of the power transformer that its secondary voltage dropped, its ripple component increased, its ability to contain its magnetic field reduced to the point of radiating the field across the input circuitry and output transformer, which then coupled it to the speakers.

The Parts of a Power Supply

Transformers Power transformers are used to isolate, to convert, and to filter the wall voltage. A transformer is made up of at least two tightly coupled coils, which usually enshroud a ferromagnetic core. The coils are both physically close and electromagnetically coupled. By means of the electromagnetic induction, AC voltage is transformed from one voltage to another from one coil to another, while the frequency remains the same. If the voltage on the primary and the secondary equal, the transformer is called an isolation transformer. If the voltage increases, the transformer is called a step-up transformer; if it decreases, a step-down transformer. The ratio of turns in each winding determines the ratio of voltage change. Thus, if the primary winding, the winding that is connected to the wall outlet, has a hundred turns and the secondary winding, the winding that feeds the rectifying circuit, has a thousand turns, the winding ratio will be 1 to 10, or 1:10, which means that the transformer will step up the wall voltage by a factor of ten. As there are no free lunches in physics, if the voltage increased by tenfold on the secondary, the current must decrease by tenfold. In other words, the winding ratio specifies the voltage ratio and the inverse of the current ratio.

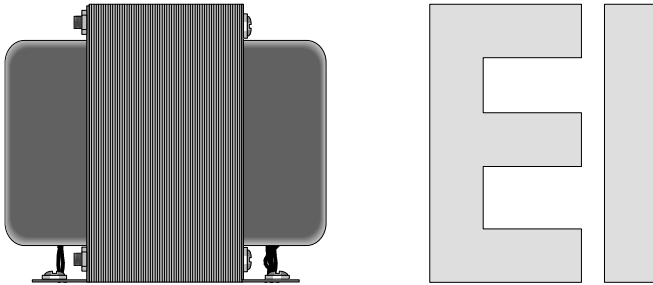

Standard EI-Core Transformers Most tube power supplies use an EI-core transformer. The outer appearance of this transformer may be an industrial looking open frame construction or classic tube amplifier end bell style or a shiny potted case. Nonetheless, internal to each is a ferromagnetic core, which is made up of flat, thin, pieces of soft iron called laminations that come in two shapes: an E and an I. These two shapes are placed side by side so as to define a closed H shape. One E is followed by one I on the layer, but on the next layer an I is followed by an E, then back to an E followed by an I for the next layer and on and on...until the desired thickness is achieved. This interlacing of E's and I's makes for an electromagnetic circuit almost as tight as a core made of solid iron.

This begs the question: Why not use a core of solid metal instead of the many laminations? The answer lies in the fact that a solid core would suffer from a deleterious effect known as Eddy currents. These electrical currents rob the transformer of efficiency. Imagine a doughnut made of iron, around a section of which several turns of wire have been wound. Now, if a DC current is applied to the winding, the induced lines of magnetic flux will circle the around the core, like bb's in a hula hoop, which is what we desire. But the same circling induces an electromagnetic field within the core itself, which creates perpendicular currents in the core material. These currents, as they only generate heat within the core material, drag down the power transfer.

Fortunately, Eddy currents are proportional to the square of the core thickness. Therefore, if the core is made thin enough, we can ignore the Eddy currents. This what the laminations do, as they are very thin and electrically insulated from each other by wax or shellac.

Large and heavy, typical EI-core transformers do not seem suited to modern sleek and slender enclosures. Additionally, they present relatively higher winding DC resistances and, as a result, deliver a more load-dependent secondary voltage. Their greatest failing, however, is the large radiated magnetic fields that emanate from the bell sides of the transformer. In other words, placement of this type of transformer within a chassis is critical, as hum can be injected into an otherwise quiet circuit by a ill-placed transformer. Yet, in spite of all of this, EI-core transformers often set the standard in audio gear and should not be demised out of hand.

Flat Pack Transformers Often mounted on printed circuit boards, these fairly modern designs pack a good amount of power in a small package. Wider and longer than they are tall, the flat pack transformer is also made up of E and I laminations and four bobbins of wire. This last feature is what most interests us. Most transformers have one winding, primary and secondary, sitting on top the other, as it helps to further couple them. The disadvantage of such an arrangement lies the increased capacitive coupling afforded by the closeness of the windings. This capacitance will couple undesirable RFI noise from the primary to the secondary. In contrast, the flat pack's greater distance between the primary and the secondary greatly reduces the capacitive coupling between windings; thus, greatly reducing the RFI transference. (The core is just too slow to react to the extreme high frequencies of the RFI.)

Flatpack



Toroidal



Toroidal Transformers Theoretically, the toroid is one of best choices of the easily available transformers. But, like so many good theories, practice proves difficult. First, the attributes: low radiated magnetic fields, better regulation, smaller, lighter, and cooler running. The obvious downside is higher cost. Where a conventional EI power transformer can be easily and quickly assembled by simple machines, toroids require much more labor and elaborate machines. The next disadvantage is surprising: toroids can be dreadfully noisy, not in terms of magnetic fields, but in terms of mechanical buzzing. Even the wire itself can buzz. Finding a low-mechanical-noise toroid can be quite difficult. Additionally, toroids often pass much more RFI than a comparable clunky EI power transformer would. Because the toroid's primary and secondary lie next to each other, there is more capacitive coupling between the windings.

Furthermore, toroids easily saturate in the presence of a sustained DC current through a winding. Because the magnetic circuit is so tight in a toroid, any DC current flow can magnetize the toroidal core, thereby robbing the transformer of its effectiveness. In other words, toroids are perfect, except that they aren't. My recommendation is to only use a toroidal power transformer when you have no other choice because of space limitations. And when you do use one, be sure to use it conservatively (which means that much of the smaller size benefit will be lost because of larger toroid being used).

Rectifiers

Rectifier only allow unidirectional current flow, an attribute needed in converting AC into DC. Tube and solid-state rectifiers can be used in high-voltage power supplies, but the vacuum tube's limited current rating and high voltage drop prohibits its use in a low-voltage power supply. One great advantage the tube rectifier holds over its solid-state brother is its slow turn on (not all tube rectifiers are slow to conduct, however); additionally, tube rectifier can more often survive high-voltage surges from the wall-socket or inductive kickbacks. Sonically, tube rectifiers usually win in shootouts, but the best solid-state rectifiers, such as HEXFREDs, easily beat the worst tube rectifiers.

Capacitors

Just as a resistor is the practical embodiment of pure resistance, a capacitor is the practical embodiment of pure capacitance. Unfortunately, a perfect embodiment is difficult to produce. The lead wires and electrodes/plates have some resistance and all physical dielectrics (the stuff between the electrodes/plates) have some conductance.

The dielectric material acts as an amplifier of sorts, as it "amplifies" the small capacity to hold a charge that would otherwise exist in its absence. By allowing a small capacitor to hold a large charge, however, the dielectric's imperfections are also "amplified." Since most materials change both in shape and in resistance with temperature, we would expect many actual capacitors to degrade in performance with changes in temperature and they do. In other words, a perfect capacitor could be made if no material were used in its construction, just as perfect society could be formed if it were not populated with people. Therefore, the dielectric makes for the biggest deviation between the perfect capacitor and the actual capacitor.

In a power supply, the capacitor stores and smoothes the rectified DC voltage. In between audio stages, a coupling capacitor freely passes the AC signal while isolating the different DC levels. As can be expected, each function demands its own preferred capacitor style, with the power supply capacitor relying on its quantity of capacitance and the AC signal transferring capacitor relying heavily on the quality of the capacitor. A capacitor has four frequently published specifications: its amount of capacitance, its voltage limit, its temperature limit, and its tolerance. An added piece of information is the polarity indicator on polarized capacitors, such as electrolytics.

Voltage Limits Capacitors often bear two voltage ratings on their bodies: a DC rating and an AC rating. The AC rating will be the lower of the two. A sinusoidal wave peaks at 1.4 times its equivalent DC voltage. Consequently, if the capacitor only bears one voltage rating, assume that it refers to the DC rating and de-rate the capacitor when using it in an AC application.

Here's an extreme example. Fearing ultra-high-frequency noise on the power supply's output, an audiophile places a small-valued capacitor across the power transformer's secondary. Now, since the power supply yields a nominal 400-volts, a 400-volt high-frequency-shunting capacitor is soldered in place, say 0.1- μ F. But as the power supply comprises a full-wave center-tapped-transformer arrangement, the capacitor sees not 400-volts, but 800-peak-volts! Even worse, if a large choke connects directly to the diodes (choke loading), then the peak voltage across the leads is 1130-volts, not 400-volts. Considering that the wall voltage may hold momentary peaks of much higher voltages, a safe rating might be 1600-volts, quite a distance from 400-vdc.

Temperature Limits There has to be a temperature limit to every capacitor, as no capacitor can survive on the Sun's surface for example. With film capacitors, such as Mylar or polystyrene, the temperature-limit is seldom printed on their bodies, although this limit can be found in the manufacturer's spec sheet for the capacitor. Because plastic films melt at a much lower temperature than do glass, mica, porcelain, or ceramic, care should be taken not to momentarily overheat film capacitors during soldering, particularly with polystyrene capacitors. For example, a 1% capacitor can easily be thrown off a few percent by such an overheating, as the heat causes the plastic to change in shape. In contrast, electrolytic capacitors always (well, almost always) display a temperature limit. This limit should never be approached let alone exceeded, as the capacitor can be easily damaged and it just might rupture. In addition, an electrolytic capacitor's useful life expectancy is shortened drastically with excess heat, as the wet part (the electrolyte) evaporates with heat, leaving the capacitor greatly reduced in capacitance.

Equivalent Series Resistance (ESR) Ideally, a capacitor should hold no ESR, as an ideal capacitor dissipates no heat and loses no voltage across its leads, but most capacitors do both. Real capacitors are made with metal, thin metal at that, so we should expect some resistance due to the metal, from the leads, the electrodes, and the slight resistance from the solder that binds the leads to the electrodes, but not the dielectric effective residual resistance. Plastic film-foil capacitors display a lower ESR than metalized-film capacitors, as foil has a lower resistance. Placing multiple capacitors in parallel lowers the effective ESR.

Heat is the capacitor's enemy. So keeping a capacitor cool is important and ESR works against us. High ripple current causes a capacitor to self-heat, just as a resistor would facing the same currents. A capacitor's construction, unfortunately, limits its heat transfer to its surroundings. The heat dissipation in a capacitor is equal to $I^2 X$ ESR, where I is the RMS ripple current.

Equivalent Series Inductance (ESL) Like ESR, ESL represents the inductance in series with the capacitance in the capacitor. This is an important consideration for high-frequency power supply filtering and other high-frequency applications as well. Placing multiple capacitors in parallel lowers the effective ESL, but the best plan might be to use specially-designed high-frequency electrolytic capacitor instead.

Dissipation Factor (DF) DF is equal to ESR/X_C . DF is much more important in power supply applications than it is in signal-coupling applications. DF is used in predicting the amount of heat a capacitor will dissipate.

Quality Factor (Q) The inverse of DF is the quality factor (Q). Thus, $Q = ESR/X_C$.

Electrolytic Capacitors This type of capacitor displays the poorest temperature stability, the most leakage, the most noise, and the shortest lifespan of any capacitor. NASA prohibits the use of electrolytics in space flight, because of high failure rate and their possible venting of noxious fluids and gases. The reason we put up with the electrolytic is because of its volumetric efficiency; we hunger for capacitance, lots of capacitance. A tube power amplifier's power supply needs at least 50- μ F and solid-state amplifier's need closer to at least 10,000- μ F. But a polypropylene 10,000- μ F capacitor would be hugely expensive (more than most cars) and hugely bulky (about the size of a small car). So instead we make do with the electrolytic. And it must be admitted: electrolytic capacitors have increased in quality substantially over the last decade.

All electrolytic capacitors belong to the polarized group and none should ever be reversed biased, i.e. hooked up backwards, as the capacitor conducts extremely well in the reverse direction. In fact, as little as 0.4 volts (depends on capacitor temperature) of reversed voltage can damage an electrolytic permanently. This brings up the issue of the electrolytic's short life span, which is measured in thousands of hours, as in 2,000-hrs. Long life electrolytics might be good for 4,000-hrs. Why so short a lease on life? Basically, the volumetric efficiency came at a price. No doubt some are thinking that a lifespan of just 2,000 hours sounds far too short, as they own 40 year old stereo equipment, stereo equipment filled with electrolytics, stereo equipment that still works. The answer lies in what the 2,000-hour life span means. The life rating spells out how long the capacitor will survive under its maximum voltage and temperature ratings. Reducing the applied voltage by only 20% increases its lifespan by threefold and reducing the applied voltage by 50% increases its lifespan by 8 times. The formula for estimating electrolytic capacitor life is:

$$L = L_R \times (E_R/E_O)^3 \times 2^{(T/10)}$$

where,

L = the estimated resulting lifespan

L_R = the life at rated limits

E_R = rated voltage limit

E_O = operating voltage

T = rated temperature minus core temperature in C

Capacitor life roughly doubles for each 15°C reduction in operating temperature; so if the electrolytic capacitor is used in a cool environment at a reduced voltage, the capacitor lifespan should exceed the useful life of the piece of equipment. Unfortunately, with tube equipment that turns out to be a big "IF," as the high-voltage and many heat radiating parts work against us. For example, a solid-state amplifier with a 30-volt power supply rail would most likely use a 50v electrolytic capacitor, which means that the B+ voltage is only 60% of the capacitor's maximum rating. On the other hand, to make the same ratio, a tube amplifier with a 450-volt rail would need a 750v capacitor, which is unlikely. More than likely, a 450v or 500v capacitor would be used, giving only a 0% to 10% voltage safety margin.

Paradoxically, electrolytic capacitors must be used so as not to go bad. When left uncharged, the electrolytic capacitor loses capacitance over time and must be "reformed" to restore its full capacitance and reduce its leakage.

Reforming of the dielectric requires applying a current limited voltage to the capacitor, until the excessive current draw falls off. Usually, a high-ohmage resistor, say 1-10-meg, is placed in series with the capacitor and a variable voltage power supply set to the capacitor's maximum voltage. Once the voltage drop across the resistor falls to a reasonable level, the capacitor will have been reformed. This can take as little as one minute or hours. I recommend not using old electrolytic capacitors or at least throwing away any capacitor that takes over 10 minutes to form. The resistor will get hot, so avoid touching it and wear safety goggles when you form old electrolytic capacitors. And never plug-in and turn on an old piece of electronic equipment that hasn't been used for decades or even years, as the electrolytic capacitors might vent or even explode. Instead, plug the equipment into a variac and slowly bring up the voltage over a few minutes. This procedure works well with solid-state equipment or tube gear with solid-state rectifiers, but less well with tube rectifier based gear. The work around is to tack solder high-voltage solid-state rectifier across the tube rectifier's socket pins and slowly bring up the voltage to about 80% of the wall voltage (100% could damage the capacitors, as the solid-state rectifiers yield higher voltages); then turn off the unit and discharge the capacitors before removing the solid-state rectifiers

Types of Electrolytic Capacitors

Electrolytic capacitors are a headache, but not all electrolytic capacitors are equal. The capacitor manufacturers have developed several optimized electrolytic capacitors that are worth looking into:

Computer Grade Big and blue, these capacitor stand out. The computer grade electrolytic capacitor gives up volumetric efficiency for reliability. This capacitor is designed to take a beating from high ripple currents. Their use is limited to the power supply.

HF Electrolytic Panasonic and others make electrolytic capacitors that trade some volumetric efficiency for improved high frequency behavior. ESL is reduced in these capacitors, making them effective at higher frequencies than a generic electrolytic capacitor. Highly recommended for cathode resistor bypassing, power supply use, and as coupling capacitors in OTL amplifiers. Unfortunately, they are usually only available up to 100-volts.

Low ESR Electrolytic ESR and high current do not go together. Consequently, low ESR capacitors are useful as a power supply reservoir capacitor, as this capacitor must see a high ripple current.

Photo Flash A special type of electrolytic capacitor, these capacitors were designed for use with a camera's flash unit. They store a relatively large high-voltage electric charge and they can deliver the charge quickly, which handsomely suits the needs of a flash bulb. What about audio; how well do these capacitors work with tube equipment? Fairly well is the quick answer, if a few key provisions are followed. The photo flash capacitor's large volumetric efficiency betrays that these capacitors cannot tolerate a steady and heavy use. Using them near their rated voltage or rated temperature is sure to shorten their life. So too using them in a power supply, as the main filter capacitor, is sure to kill them.

So what good are photo-flash capacitors? These capacitors are quite suitable for low-ripple power supply use; say for the first stage of an amplifier's RC filter, after being fed by a high-ohmage voltage-dropping resistor. Another use is as the output coupling capacitor in an OTL amplifier. In fact, one OTL manufacturer found that they worked perfectly in that position. Wouldn't the high current demands of the loudspeaker ruin this capacitor? No, although the current peaks can be quite high, unless you are exclusively listening to organ music at high volumes, you are not actually delivering very much steady current into the loudspeakers.

Bypass Capacitors Because the power supply workhorse known as the electrolytic capacitor is so clunky, many advocate bypassing it with a smaller-valued, high-quality film or oil capacitor. This can work supremely well, but it can also backfire. Many electrolytic capacitors present a large amount of inductance (ESL), which will oscillate in combination with a pure capacitance, which many bypass capacitor approach. The workaround is to place a resistor in series with the bypass capacitor (usually equal to the electrolytic capacitor's ESR).

Two high-voltage capacitor in series High-voltage capacitor can be hard to find, particularly if the voltage rating needs to be over 450V. This predicament can be overcome by placing two high-voltage capacitor in series, which effectively doubles the voltage rating, but halves the total capacitance. The danger in trick lies in the capacitors not uniformly charging up, which will expose one to excessive voltage, thereby destroying or damaging the capacitor. The workaround is to place a high-voltage, high-wattage, high-ohmage (100k to 1M) resistor in parallel with each capacitor in the series. These added resistors will work to prevent dissimilar voltage drops across either capacitor, dividing the DC voltage equally between capacitors.

Capacitor Safety

- Always assume that capacitor holds charge and you will never be shocked to find that in fact it did. Oil capacitors are notorious for retaining a large charge after having been discharged.
- Always use a resistor to short out a capacitor and never short the capacitor's leads together, as the capacitor's own lead wire can melt and sputter from a heavy discharge without the current limiting that the resistor imposes.
- Always observe a polarized capacitor's orientation, as some polarized capacitors have gone off like little hand grenades after being inserted backwards.
- Always shroud the exposed leads of high-voltage capacitors to reduce possible shorts or shocks.
- Always ensure adequate clamping of any axial capacitor much larger than 5-watt resistor, as an unsupported heavy capacitor will bounce and jiggle with vibration or movement and break free of one its leads. This is particularly true with power supply capacitors, as the constant vibration from the power transformer can cause the capacitor's leads to fatigue and snap.

Rectifier Circuits

Tube equipment was born to run on DC and everywhere it is chained to AC wall sockets. In other words, all power supplies that plug into wall sockets, must convert AC voltage to DC voltage. This conversion requires rectifiers and capacitors; and there are several ways that the rectifiers can be configured.

Full-Wave Bridge This is the most popular power supply configuration. The entire secondary winding is used and four rectifiers are required. This configuration is seldom used with tube rectifiers, as the rectifier cathodes cannot be heated by just a single heater winding. The two diode voltage-drops mean little in a high-voltage power supply, but are a big liability in low-voltage power supplies.

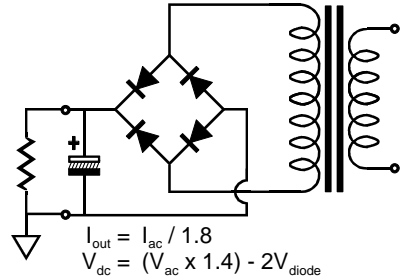

Full-Wave Center-Tap This is the classic tube amplifier power supply configuration. It uses only half of secondary winding at a time and requires a center-tapped winding and two rectifiers, saving two compared to the full-wave bridge configuration. On the other hand, the two rectifiers will see twice the peak reverse voltage that four rectifiers would see in a full-wave bridge configuration, which can greatly limit the use of solid-state rectifiers in high-voltage power supplies; in addition, the secondary is only about 75% as effectively utilized in this configuration compared to the FW bridge circuit. Paradoxically enough for what many consider a purely high-voltage circuit, this rectifier circuit is often used in extremely low-voltage power supplies, as the single-diode voltage drop greatly increases this circuit's efficiency.

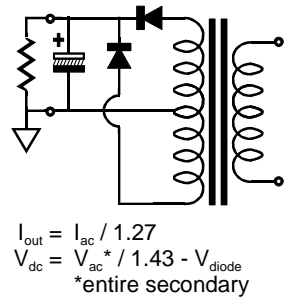

Full-Wave Choke Input This power-supply configuration is often used with tube rectifiers and requires quite a bit of tuning. When designed correctly, this power supply topology yields the flattest output voltage over a wide range of current draw, as the power supply capacitor is charged by a near square waveform. On the other hand, the large choke will be expensive, heavy, and given to loud mechanical noise. This circuit requires a relatively low-valued bleeder resistor to keep the output voltage from peaking dangerously high at turn on.

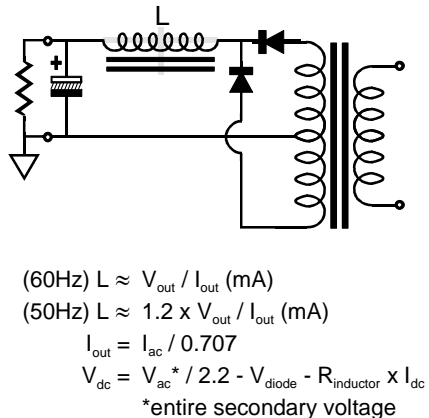

Voltage Doublers

Full-Wave Voltage Doubler Although often shunned by tube fanciers, there is nothing wrong with this power supply configuration. The full-wave voltage doubler circuit doubles the voltage that a full-wave bridge rectifier circuit would provide, but with only half the output current capability. And the ripple is at the same 100Hz or 120 Hz frequency as in the full-wave bridge rectifier circuit.

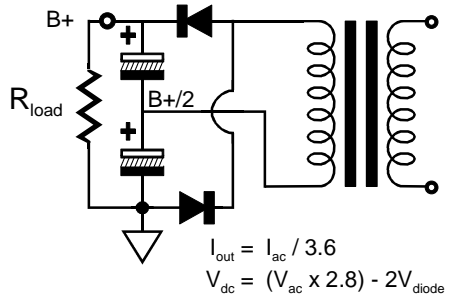

In this circuit, the transformer core is not partially magnetized as it is in simple half-wave power-supply circuits, as the secondary charges one capacitor during one half of the cycle and then in the second half of the cycle, it charges the second capacitor. Because these capacitors are in series with each other, the voltages and frequency of the noise double.

Now, what normally happens in a full-wave-bridge power supply is that the current flows through the secondary winding in one direction on one half of the AC cycle and then it flows in the other direction the other half of the cycle: up, down, up, down. But in the simple half-wave voltage rectified power supply, the current will flow through the secondary winding in one direction on one half of the AC cycle and then it not flow on the other half of the cycle: up, off, up, off. These repeated single direction conduction cycles are similar in effect to hooking up a DC voltage source across the transformer's secondary, which would definitely work to magnetize the transformer's core. Thus, simple half-wave rectifier circuits should only be used where little current draw is expected, such as in establishing a negative bias voltage power supply.

Half-Wave Voltage Doubler The principle of operation for a half-wave voltage doubler, however, is different from that of the simple half-wave rectified power supply, being much closer to the full-wave rectifier circuit. They share the "half-wave" name because of same noise frequency and half cycle charging of the output capacitor, but not because of the conduction cycle through the secondary.

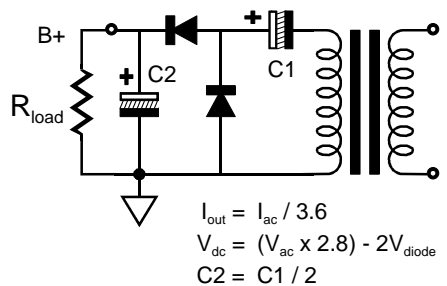

The half-wave voltage doubler's transformer conducts through both halves of the AC cycle just like the full-wave bridge rectifier circuit. On the first half of the cycle, the capacitor attached to the transformer's secondary is charged and the output capacitor receives no charging. On the second half, the both capacitors are charged simultaneously. So the transformer's secondary experiences a current conduction on both halves of the cycle and is thus not subject to the magnetizing of its core. In contrast, the full-wave voltage doubler circuit, while it does experience conduction through both halves of the cycle, works differently from the half-wave version.

Voltage Regulators

A voltage regulator is an electronic circuit that strives to maintain a constant output voltage—in spite of variations in either the wall voltage or the current drawn by the load. A voltage regulator does with complex circuitry what a car battery does by brute force: it maintains a steady and accurate output voltage over a large range of load current. Regulators fall into two groups: switching and linear. In terms of sales, flexibility, conversion efficiency, and weight to power output, the switching regulator beats the linear regulator. Yet, the switching regulator is rarely used in high-end audio products. Why? Because of noise, high-frequency noise. Switching regulators operate at supersonic frequencies, 40kHz and much higher; and these high frequencies can easily escape and pollute the rest of the circuit.

Linear Regulators Linear regulators, on the other hand, are relatively inefficient; but are also lower in noise, require fewer parts, and are usually much less complex and finicky than a switching regulator. For example, an excellent 1A, 5-volt linear regulator in a three-pin package that requires few supporting parts can be had for less than a quarter. Linear voltage regulators further subdivide into series and shunt regulators.

Series Regulators The series regulator is the overwhelmingly most used voltage regulator—for good reasons. A series regulator is like a class-B amplifier: it does not dissipate power unless it required to. For example, if the tubes are pulled from an amplifier, the series high-voltage regulator stops conducting until the tubes are plugged in again. When the amplifier is drawing full current from the power supply, the series regulator is at peak dissipation.

Shunt Regulators In contrast, the shunt regulator is like a class-A amplifier: it is always on, it dissipates the most power at idle, and it is unburdened when power is shifted into the load. For example, if the tubes are pulled from an amplifier, the shunt high-voltage regulator must increase its conduction (and thus its dissipation) to compensate for the current that the tubes had drawn. When the amplifier is drawing full current from the power supply, the shunt regulator is at its lowest dissipation.

Shunt regulators offer many sonic advantages over series regulators; they usually find a shorter and cleaner path to the ground reference, and they absorb noise rather than transmit it, but at the cost of decreased efficiency. Inefficiency, however, is something with which tube audio designers have learned to accept and some believe to be virtue: “the less efficient, the better the sound,” as they say.

The principle of operation of a shunt regulator in AC terms is simple enough: the noise signal on the output is compared to ground, then the current through the shunt regulator’s active current shunting device is varied in response to that signal, and then, in turn, this current develops a varying, inverting voltage across a series resistor or choke that cancels this same signal. In DC terms: the power supply rail voltage is compared to a voltage reference and the idle current through the shunt regulator is varied to bring the power supply voltage in line with the reference. Like the series regulator, the shunt regulator needs three elements to work: a shunting device with a variable conductance, a voltage reference that is AC bypassed to ground, and a feedback mechanism to control the flow of current through the shunt regulator. Amazingly enough, the triode comprises all three elements at once.

PS - 4

High-Voltage Schematic

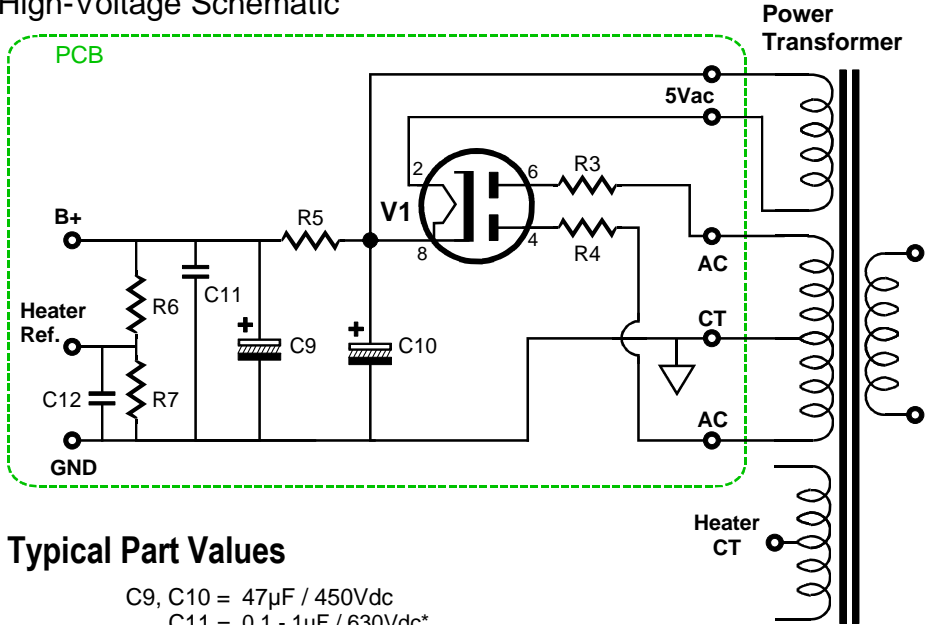

Typical Part Values

C9, C10 = 47 μ F / 450Vdc
 C11 = 0.1 - 1 μ F / 630Vdc*
 C12 = 0.01 - 0.47 μ F / 160Vdc
 *400Vdc voltage rating can be used, if B+ <= 350V

R3, R4 = 100 to 300 ohms / 1W - 2W
 R5 = 100 - 10k / 2W - 5W
 R6 = 300k / 1W
 R7 = 100k / 1W

V1 = 5AR4 or 5R4 or 5Y3 or WE274B

V1 Heater Vac = 5V@2A
 (B+) Vac = 400Vac to 600Vac (requires center-tap)*

*Current rating depends on load. Usually, 50mA to 100mA is adequate.

The limiting factors are the 5W series resistor (R5), the 47 μ F/450V power supply capacitors (C9 & C10). The power transformer's selection is somewhat critical, as too high a primary voltage will create too high a B+ voltage. Unfortunately, most high-voltage power transformers are truly high-voltage, offering far too much secondary voltage. Remember that power supply's output voltage will be much higher when the power supply is unloaded; for example, when the tube-based audio circuit it powers is still cold and warming up. In general, high voltage power transformer exhibit very poor regulation, thus extra care must be taken to prevent exposing the power supply capacitor to excessive voltage.

Heater Power Supply & Regulator

The PS-4 PCB also holds a low-voltage power supply and voltage regulator. Below is the heater power supply schematic used on the PS-4 PCB. As can be seen, the power supply can accept many different rectifier configurations: full-wave bridge and full-wave center-tapped and full-wave voltage doubler. In other words, this regulator can deliver +6.3Vdc from three different power transformer secondary voltages, 5Vac, 7Vac, or 12Vac CT; or 12.6Vdc from a 6.3Vac, 12.6Vac, or 24Vac CT primary.

When used as a full-wave-bridge or a full-wave-center-tapped rectifier circuit, the two power supply filtering capacitors are oriented with their positive leads pointing to the top of the PCB, where the heatsink sits; configured as a voltage doubler, these capacitors are rotated 90 degrees clockwise, so the positive leads point to the right edge of the PCB

Full-Wave Bridge

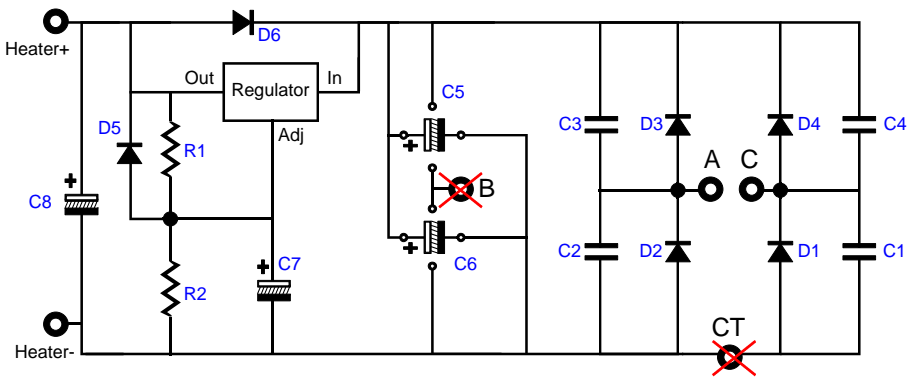

Capacitor C5 & C6 positive leads pointing to heatsink
Fullwave-Bridge Rectification. Raw DC voltage = 1.414Vac - 2V
AC voltage is applied to pads A and C only.

Full-Wave Center-Tap

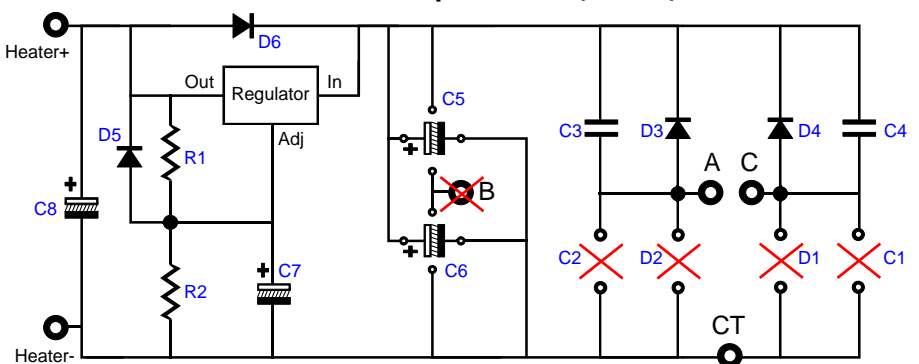

Capacitor C5 & C6 positive leads pointing to heatsink
Fullwave-Bridge Rectification. Raw DC voltage = 1.414Vac - 2V
AC voltage is applied to pads A and C only.

The PCB can even accept a full-wave center-tapped configuration. The main advantage behind using a center-tapped power transformer is that the rectification only loses one rectifier voltage drop, rather than the usual two drops. A 1V versus a 2V voltage drop can make a decisive difference in a low-voltage regulated power supply, such as a 5V regulator.

Due to rectifier losses and the need for regulator voltage headroom, the popular 6.3Vac heater winding is just too low to realize a 6.3Vdc regulated output voltage. Fortunately, the PS-4 PCB can be configured to create a voltage doubler, effectively doubling the 6.3Vac to 12.6Vac, which allows a 12Vdc or 12.6Vdc output. Note the change in capacitors C5 & C6's position; the capacitors are no longer in parallel, but in series. Since only two rectifiers are used in the voltage doubler circuit, rectifier bypass capacitors, C1 & C4, are also not needed.

Voltage Doubler

AC input to pads A & B

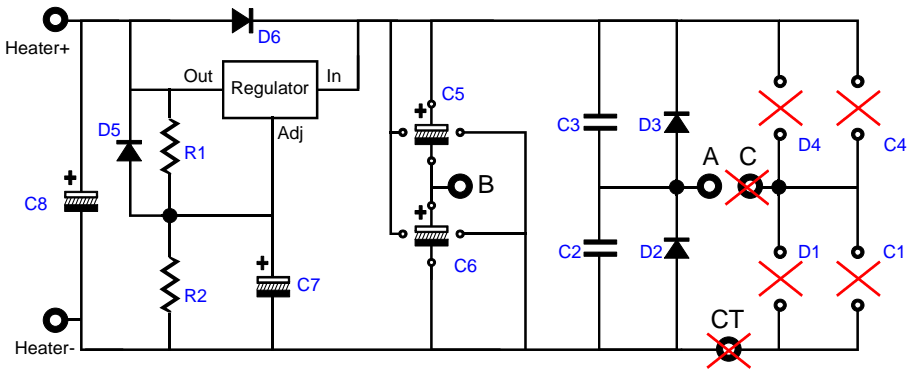

Capacitor C5 & C6 positive leads pointing to tube rectifier
 Fullwave-Voltage-Doubler Rectification. Raw DC voltage = 2.828Vac - 2V
 AC voltage is applied to pads A & B only; D1, D4, C1, C4 are left off PCB.

Typical Part Values

- C1, C2, C3, C4 = 0.01 μ F - 50V
- C5, C6 = 10,000 μ F - 16V
- C13, C14 = 1k μ F - 16V
- D1, D2, D3, D4 = MUR410G
- R1 = 124
- R2 = 499 ohm for 6.3Vdc
- 1.07k for 12Vdc
- 1.13k for 12.6Vdc

Regulator = LD1085 or LM350 or LT1085

- Vac Input = 7-8Vac for 6.3Vdc (FW Bridge)
- 12-12.6Vac CT for 6.3Vdc (FW Bridge CT)
- 12-12.6Vac @ 2.5A for 12Vdc or 12.6Vdc (FW Bridge)
- 24-28Vac CT for 12Vdc or 12.6Vdc (FW Bridge CT)
- 6.3-8Vac for 12.6Vdc (Voltage Doubler)

Modifications & Part Upgrades

Tubes The rectifier offers a widest and easiest choice of suitable replacements, such as the 5AR4/GZ34, 5R4GB (avoid the version with the large bulbous base), 5Y3, and even the staggeringly expensive WE274.

Resistors & Capacitors The range of prices for resistor and capacitor is huge, with resistors costing as little as \$0.02 and as much as \$25. Fortunately, the PS-4 is quite economical in its number of critical parts. Resistor R5 and capacitors C9, C10, C11 are the most sonically important.

Power Transformer Most will desire using a single power transformer, but using two power transformers, one for the heater power supply and one for the high-voltage B+ power supply, holds real merit. Why two? Imagine a single power transformer; the low-voltage solid-state rectifiers and large-valued capacitors in the heater power supply will allow huge current surges that occur for in only brief spurts, while charging its power-supply capacitors. These large current-conduction spikes can easily couple to the B+ winding, as the two windings share the same core. But when you use two power transformers, the heater power supply's current spikes are isolated, applying to only its separate transformer. In addition, two power transformers allow a staggered turn on, wherein the heater power supply can be turned on first before applying the B+ voltage. Moreover, the single power transformer that was adequate to power four 6SN7s with AC on the heater may longer prove adequate when it must deliver rectified DC, due to the losses involved in rectification and regulation.

Operation

Grounding Laying out the ground wires in an audio piece of equipment is both a science and an art. The best procedure is to avoid ground loops by using a single star ground, which may hold several ground spurs, say one for each channel in a dual-mono setup, with two sets of hookup wire leading to the PS-4 PCB. Be sure to attach only the ground pad (and the B+ pad) at the top of the PCB to the audio circuits being powered, using tightly twisted wires. See page 19 for much more information on grounding. The chassis should also be grounded; attach a wire from the PS-4 high-voltage CT pad to the chassis where the AC power enters the chassis.

Staggered AC With this optional setup, you can turn on the heaters first, so the tubes are given a chance to heat up, which will create an electron cloud over the cathodes, protecting them from the B+ voltage. Two switches (and possibly two power transformers) will be needed.

Fusing Usually a fuse is placed in series with the power transformer's primary, but both the B+ output and the heater output can receive a fuse as well. Use a slow blow fuse for the heater and quick blow fuse with the B+ output.

Caution Do not touch the heater regulator's exposed metal tab while powered, as it will be both extremely hot and possibly charged to 1/4 the B+ voltage; it can be a shock hazard. In other words, test with probes before you touch with your fingers. In addition, give the PS-4 regulator lots of room and good air flow to wick away heat.

Assembly & Testing

Assembly Cleanliness is essential. Before soldering, be sure to clean both sides the PCB with 90% to 99% isopropyl alcohol. Do not use dull-looking solder; solder should shine. If it doesn't, first clean away the outer oxidation with some steel wool or a copper scouring pad. If the resistor leads look in the least gray, clean away the oxidation with either steel wool or a wire sniper's sharp edges. Admittedly, with new resistors and a fresh PCB, such metal dulling is rare; but if the parts have sat in your closet for a year or two, then expect a good amount of oxidation to have developed.

First, solder all the small diodes in place, and then solder the resistors, rectifiers, capacitors, and heatsinks. Be consistent in orienting the resistors; keep all the tolerance bands on the resistor's body at the right side as you face the resistor straight on. This will pay dividends later, if you need to locate a soldered resistor in the wrong location. Because the board is double sided, with traces and pads on each side, it is easier to solder the resistors from their top side. As the PCB is so overbuilt, it is extremely difficult to remove an incorrectly placed part. Be sure to confirm all the electrolytic capacitor orientations, as a reversed polarized capacitor can easily vent (or even explode) when presented with high-voltage. Confirm twice, solder once.

It is often easier to attach the LD1085 (low-voltage regulator) to its heatsink first and then to solder both the heatsink and regulator to the PCB at once, rather than attaching the heatsink first and then attaching the regulator to the heatsink.

Testing Wear safety eye goggles, as a venting power-supply capacitor will spray hot caustic chemicals. Make a habit of using only one hand, with the other hand behind your back, while attaching probes or handling high-voltage gear, as a current flow across your chest can result in death. In addition, wear rubber-soled shoes and work in dry environment. Remember, safety, first, second, and last.

1. Attach only the heater power supply's transformer winding, leaving the high-voltage transformer leads unattached and electrical tape shrouded.
2. Use a variac and slowly bring up the AC voltage, while looking for smoke or part discoloration or bulging.
3. Measure heater regulator's output voltage without and with a load. If the heater regulator fails to regulate or provide enough DC voltage, try either lowering the heater voltage a tad, for example 12V instead of 12.6V, as the 0.6V difference might be enough to bring the regulator back into regulation.
4. Next, power down the heater regulator and attach the high-voltage windings
5. Attach the power transformer to a variac and slowly bring up the AC voltage.
6. Measure the high-voltage output voltage without an external. The tube rectifier is slow to conduct, so be patient. The output voltage must never exceed 450V; if the voltage is greater than 400V, use a different transformer.
7. Once the tube rectifier has warmed up and stabilized, measure the AC voltage on both sides of Resistor R5; on the output side, the AC voltage should be substantially lower than on the resistor's other lead.

Only after you are sure that both regulators are working well, should you attach a line stage amplifier (or phono stage, etc.).

Grounding

Ideally, every audio circuit finds only one central signal ground point, which the rest of the circuit uses as its signal reference. Ground loops, however, are extremely easy to introduce. For example, if the input and output RCA jacks are not isolated from the chassis, then the twisted pair of wires that connect the PCB to the jacks will each define a ground loop. The solution is either to isolate the jacks or use only a single hot wire from jack to PCB (the wire can be shielded, as long as the shield only attaches at one end). Thus, the best plan is to plan. Before assembling the audio circuit, stop and decide how the grounding is going to be laid out, then solder.

Three different schools of thought hold for grounding a piece of audio gear. The Old-School approach was to treat the chassis as the ground; period. Every ground connection is made at the closest screw and nut. This method is the easiest to follow and it produces the worst sonic results, as steel, zinc, and aluminum are poor conductors.

The Semi-Star ground method uses several ground “stars” that are often called spurs, which then terminate in a single star ground point, often a screw on the chassis. This system can work beautifully, if carefully executed. Unfortunately, often too much is included in each spur connection. For example, all the input and output RCA jacks share ground connection to a long run of bare wire, which more closely resembles a snake than a spur ground. In other words, the spurs should not be defined just physical proximity, but signal transference. Great care must be exercised not to double ground any spur point. For example, the volume control potentiometer can create a ground loop problem, if both of its ground tabs are soldered together at the potentiometer and twisted pairs, of hot and cold wires, arrive at and leave the potentiometer, as the two cold wires attaching to the PCB will define a ground loop.

The Absolute-Star grounding scheme uses a lot of wire and is the most time consuming to lay out, but it does yield the best sonic rewards. Here each input signal source and each output lead gets its own ground wire that attaches, ultimately, at one star ground point; each RCA jack is isolated from the chassis.

House Ground The third prong on the wall outlet attaches to the house’s ground, usually the cold water pipe or a copper-plated steel pipe buried under the house. The audio circuit’s chassis can (and should) also attach to this ground connection, which is certainly the safest approach, as it provides a discharge path should the B+ short to the chassis. Unfortunately, this setup often produces a hum problem. Some simply float the ground, which is not safe, while others use several solid-state rectifiers in series/parallel to attach the chassis ground to the house ground (**NOT NEUTRAL**) via the third prong, and others still use a power 10-ohm resistor (or low-DCR inductor) shunted by a small high voltage capacitor.

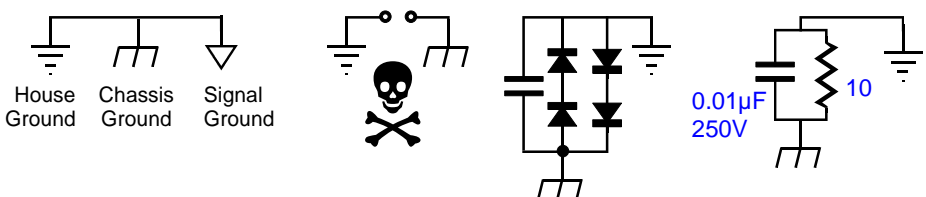

PS-4 PCB (4" by 4") Layout & Dimensions

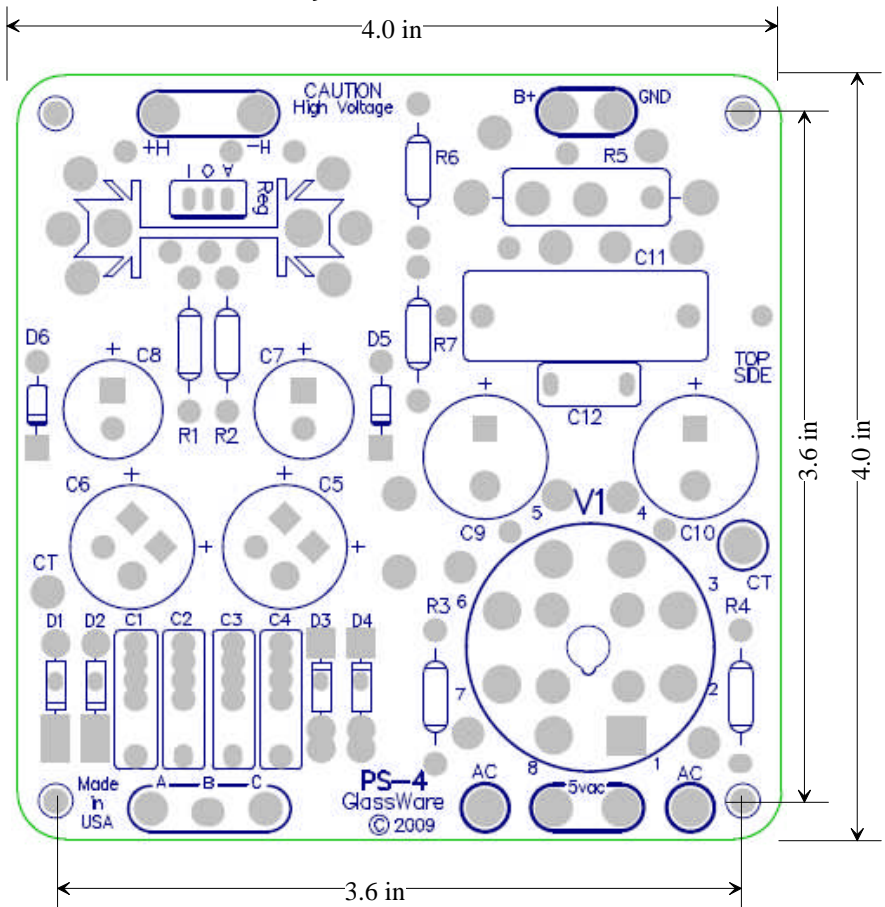

Let me know what you think

If you would like to see some new audio PCB or kit or recommend a change to an existing product or if you need help figuring out the PS-4's assembly, drop me a line by e-mail to sales@glass-ware.com (begin the subject line with either "Aikido" or "tube" or the spam filters are sure to eat your message).